

(s, 3 H, angular CH<sub>3</sub>), 1.72 (s, 3 H, allylic CH<sub>3</sub>), 4.67 (s, 2 H, C=CH<sub>2</sub>), 0.76-2.30 (m, 13 H, ring protons).

In one case the intermediate *N*-tosylurethane was isolated by cooling and filtering the reaction mixture as soon as the addition of tosyl isocyanate had been completed. The solid was recrystallized from ether and melted at 132-133 °C.

**1 $\alpha$ ,9 $\alpha$ -Methylene-7 $\beta$ -acetyl-10 $\beta$ -methyldecalin (12).** A sample of olefin 11 (1.0 g, 4.9 mmol) in 38 mL of methylene chloride and 9 mL of methanol was cooled in a dry ice-acetone bath and ozonized until a light blue solution was obtained. The excess ozone was flushed with a slow stream of nitrogen gas. Dimethyl sulfide (3 mL) was added dropwise to the colorless solution. The reaction solution was allowed to warm and stirred at room temperature overnight. Then it was washed with water (2  $\times$  50 mL) and dried over MgSO<sub>4</sub>, and the solvent was removed under reduced pressure. The residue was passed through a short column (60 g of SiO<sub>2</sub>), using 1:2 methylene chloride/hexane as the eluant, to afford 12 as a colorless liquid (0.93 g, 4.5 mmol, 92%), bp 90 °C (0.1 mmHg). The structure was assigned on the basis of spectral properties: IR (neat) 1700 (C=O) cm<sup>-1</sup>; NMR (CDCl<sub>3</sub>)  $\delta$  0.00-0.90 (m, 3 H, cyclopropyl) 1.10 (s, 3 H, angular CH<sub>3</sub>), 2.10 (s, 3 H, COCH<sub>3</sub>), 0.90-3.00 (m, 13 H, ring protons).

Anal. Calcd for C<sub>14</sub>H<sub>22</sub>O: C, 81.48; H, 10.76. Found: C, 81.79; H, 10.66.

**$\alpha,\beta$ -Cycloodesmol ( $\alpha,\beta$ -1) from Ketone 12.** To a solution of methylmagnesium iodide, prepared by dissolving magnesium turnings (24 mg, 1.0 mmol) in methyl iodide (150 mg, 1.0 mmol) and 4 mL of anhydrous ether, was added dropwise, under a nitrogen atmosphere, a solution of ketone 12 (100 mg, 0.49 mmol) in 2 mL of anhydrous ether. The resulting white mixture was allowed to stir at room temperature for 2 h and then was partitioned between 6 mL of dilute aqueous hydrochloric acid and 10 mL of ether. The ether layer was washed with two 10-mL portions of water and dried over MgSO<sub>4</sub> to give, after removal of solvent under reduced pressure, a slightly yellow oil (100 mg, 0.45 mmol, 92%). This was identified as  $\alpha,\beta$ -cycloodesmol ( $\alpha,\beta$ -1) on the basis of IR and NMR spectral comparisons with the material prepared according to Scheme I.

**Acknowledgment.** We thank the National Science Foundation for support of this research. E.Y.C. is grateful to Hoffmann-LaRoche, Inc., for financial support.

**Registry No.**  $\alpha,\beta$ -1, 76548-19-1;  $\alpha,\beta$ -1 *N*-tosylurethane, 76480-40-5; 3, 63975-59-7; 4, 76480-41-6; 5, 76548-20-4; 6, 76480-42-7; 7, 76548-21-5; 8, 76480-43-8; 9, 76480-44-9; 10, 76480-45-0; 11, 53767-96-7; 12, 76548-22-6.

## Antileukemic Alkaloids from *Taxus wallichiana* Zucc.

Roger W. Miller,\* Richard G. Powell, and Cecil R. Smith, Jr.

Northern Regional Research Center, Agricultural Research, Science and Education Administration,  
United States Department of Agriculture,<sup>1</sup> Peoria, Illinois 61604

Edward Arnold and Jon Clardy\*

Department of Chemistry, Baker Laboratory, Cornell University, Ithaca, New York 14853

Received September 30, 1980

A new antileukemic taxane alkaloid, cephalomannine (1a), has been isolated from leaves, stems, and roots of *Taxus wallichiana* Zucc. Cephalomannine is closely related to taxol (1b), a previously characterized antileukemic alkaloid, which also occurs in *T. wallichiana* but in lesser amounts than cephalomannine. The new alkaloid and its hydrolysis products were characterized by nuclear magnetic resonance, mass spectroscopy, and X-ray crystallography; taxol and two cytotoxic taxane congeners were also identified.

During a search for antitumor agents from plants, we encountered KB and PS activity<sup>2</sup> in extracts of a coniferous tree collected in the Shillong Forest of India and shipped to us under the name *Cephalotaxus mannii*. Our putative *C. mannii* contains none of the alkaloids characteristic of other *Cephalotaxus* sp.,<sup>3</sup> and its antitumor properties are associated with alkaloids of the taxane series; the plant now is considered to be *Taxus wallichiana* Zucc.<sup>4</sup> This paper describes the isolation and characterization of a new antitumor alkaloid, cephalomannine, and the iden-

tification of some other taxanes. A portion of this work has been published previously in preliminary form.<sup>5</sup>

The ethanolic extract of the ground plant material was processed in a solvent-partitioning scheme (Figure 1). KB activity was found to reside exclusively in material from the chloroform phase (F188) after chloroform-water partitioning, and this fraction was subjected to column chromatography on silica gel. This procedure afforded a series of fractions (F191-F196), most of which were KB active. We noted that analytical thin-layer chromatography (TLC) of F193 revealed a component that had an *R<sub>f</sub>* similar to that of taxol,<sup>6,7</sup> and this observation led to the

(1) The mention of firm names or trade products does not imply that they are endorsed or recommended by the U.S. Department of Agriculture over other firms or similar products not mentioned.

(2) Cytotoxic and antileukemic activities were assayed under the auspices of the National Cancer Institute by the procedures described by: Geran, R. I.; Greenburg, N. H.; MacDonald, M. M.; Schumacher, A. M.; Abbott, B. J. *Cancer Chemother. Rep., Part 3* 1972, 3(2), 1.

(3) Smith, C. R.; Powell, R. G.; Mikolajczak, K. L. *Cancer Treat. Rep.* 1976, 60, 1157.

(4) After examining leaves and woody portions of the plant, Dr. Richard Eyde of the Smithsonian Institute, Washington, DC, has tentatively reidentified our material as *Taxus wallichiana* Zucc.

(5) Powell, R. G.; Miller, R. W.; Smith, C. R., Jr. *J. Chem. Soc., Chem. Commun.* 1979, 102.

(6) Wani, M. C.; Taylor, H. L.; Wall, M. E.; Coggon, P.; MacPhail, A. T. *J. Am. Chem. Soc.* 1971, 93, 2325.

(7) Cephalomannine (1a) gave typical *T/C* values in the range 152-180 at dose levels of 1-3.3 mg/kg against PS. Taxol (1b) showed *T/C* values of 148-152 in the dosage range 1.4-2.2 mg/kg. Both compounds showed cytotoxicity (ED<sub>50</sub>) against KB cell culture at 10<sup>-3</sup>  $\mu$ g/mL, whereas baccatin III (1c) had an ED<sub>50</sub> of 2.0  $\mu$ g/mL and  $\beta$ -hydroxybaccatin I (2) had an ED<sub>50</sub> of 2.9  $\mu$ g/mL.

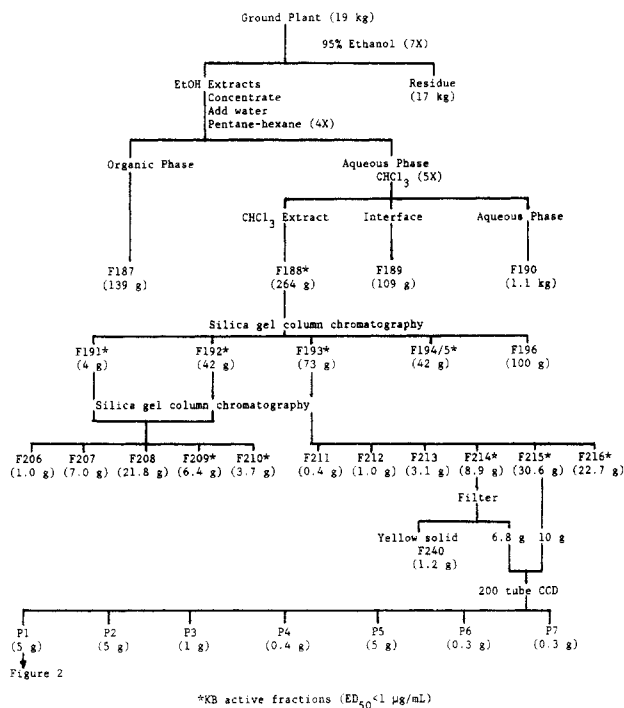

Figure 1. Separation scheme.

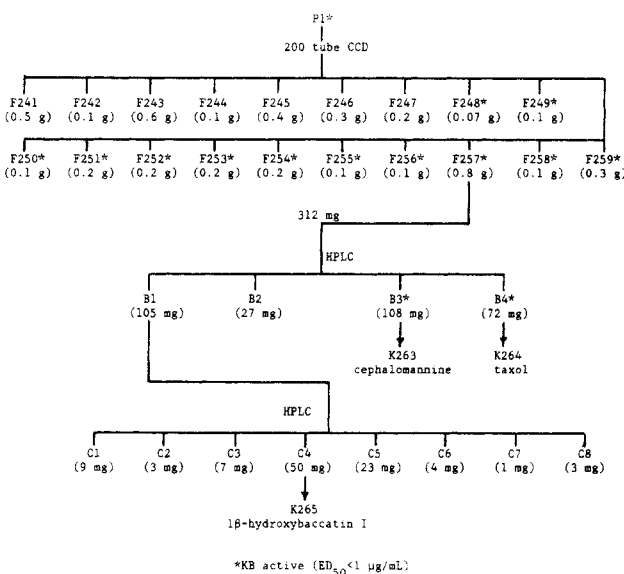
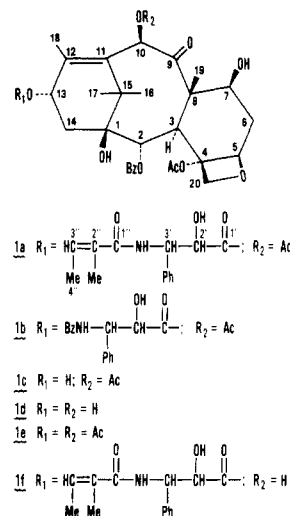

Figure 2. Separation scheme continued.

suspicion that the KB and PS activities of *T. wallichiana* were at least partly associated with taxol. A second stage of column chromatography gave a new series of fractions, two of which (F214, F215) showed TLC spots corresponding to taxol. These fractions were subjected to countercurrent distribution (CCD) in two stages (Figures 1-4).

From the second CCD (Figure 4) was obtained an active fraction which gave four subfractions (B1-B4) when subjected to high-pressure liquid chromatography (LC). B4 proved to be taxol (1b), and B3 was a new alkaloid to which we have given the name caphlomannine (1a).<sup>5,7</sup> This new alkaloid occurs more abundantly than taxol in *T. wallichiana*, the ratio being about 3:2.

Investigation of certain accumulated fractions indicated in Figure 1 and 2 resulted in the isolation of two cytotoxic taxane derivatives as well as two structurally unrelated lignans. High-pressure LC of CCD fraction P2 afforded baccatin III (1c), a 13-deacyl derivative of 1a and 1b.



Further high-pressure LC of fraction B1 yielded 18-hydroxybaccatin I (2).

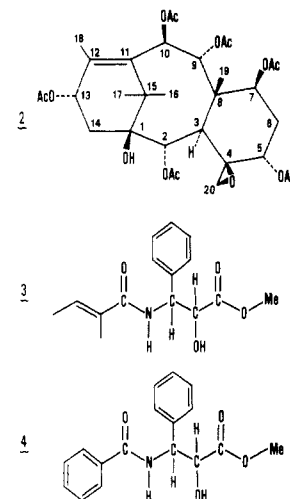

After isolation by high-pressure LC, cephalomannine (1a) crystallized as needles, mp 184-186 °C; the field-desorption mass spectrum of 1a gave a result consistent with the formulation C<sub>46</sub>H<sub>53</sub>NO<sub>14</sub>. Its proton NMR spectrum (Table I) was similar in many respects to that of taxol (1b) but differed in that it lacked part of the aromatic resonances of 1b in the δ 7.4-7.85 region.

Treatment of 1a with 1% sodium bicarbonate in methanol-water (3:1) provided a mixture of five hydrolysis products (1c,d, 3, and 5a,b) all of which were isolated by

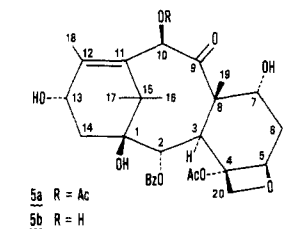

TLC and identified. Baccatin III (1c) was also oxidized with manganese dioxide at the allylic 13-hydroxyl function to give a diketone (6a) identical with one similarly obtained from taxol.<sup>6</sup> Diketone 6a was accompanied by a small amount of the epimeric diketone 6b. This conversion established the identity of the basic taxane ring system of cephalomannine. Identification of the other three taxane derivatives (1d, 5a,b) by NMR and mass spectra provided further confirmation. Methyl ester 3 also was

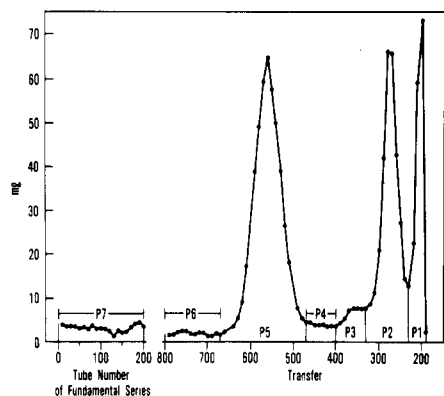

**Figure 3.** Weight distribution curve for CCD of F215 and F214 [solvent system: ethyl acetate-*n*-hexane-methanol-water (60:40:35:65)].

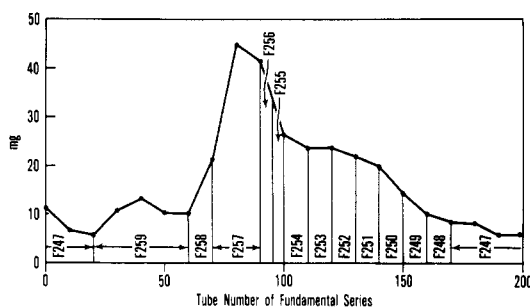

**Figure 4.** Fundamental series after 1200 transfers, CCD of transfers 110-230 from CCD of F214 and F215 [solvent system: ethyl acetate-*n*-hexane-methanol-water (40:60:65:35)].

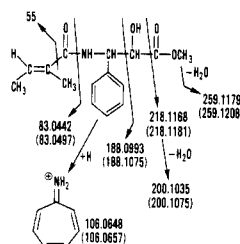

**Figure 5.** Mass spectral fragmentation of methyl ester 3 (measured mass vs. calculated mass).

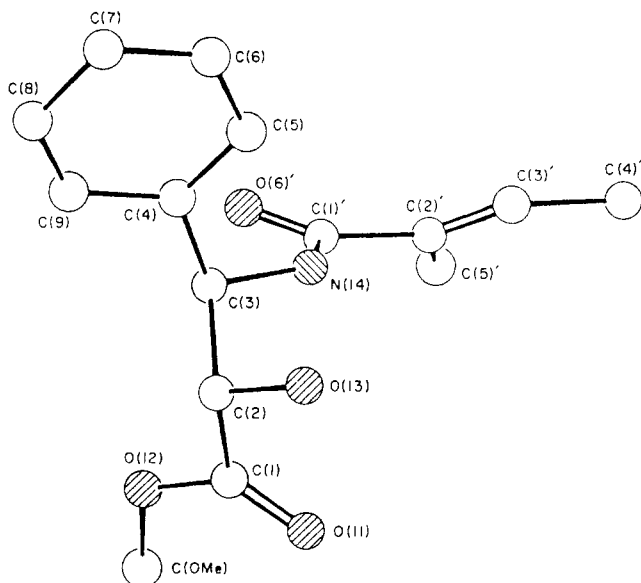

**Figure 6.** Computer-generated perspective drawing of the final X-ray model of side-chain ester 3. Hydrogens are omitted for clarity, and no absolute configuration is implied.

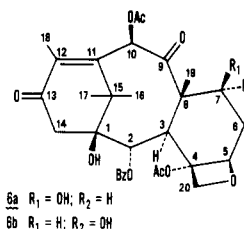

obtained after treating **1a** with sodium methoxide in anhydrous methanol; however, other products of this reaction were complex and difficult to purify.

Methyl ester **3**, derived from the nitrogen-containing ester side chain of **1a**, was obtained as a crystalline solid. The proton NMR spectrum of methyl ester **3** revealed a broadened doublet at  $\delta$  1.72 and a broad singlet at  $\delta$  1.82, both associated with vinylic methyl groups. A vinylic proton appeared as a multiplet at  $\delta$  6.48. Signals due to protons at C-2', C-3', phenyl attached to C-3', and NH of ester **3** had close counterparts in the spectrum of **4**, the methyl ester derived from **1b**. However, the aromatic absorption associated with the *N*-benzoyl group of **4** was absent. Taken together, these observations indicated that an *N*- $\alpha$ -methylcrotonyl moiety replaces the *N*-benzoyl group of the taxol side chain. Further support for this structural formulation came from mass spectral fragmentation of **3** (Figure 5) and from its IR spectrum which showed maxima at 1710 and 1640  $\text{cm}^{-1}$ , demonstrating both ester and amide linkages.

Although NMR can be used to distinguish the geometric isomers of trisubstituted  $\alpha,\beta$ -olefinic acids and their esters by using the shift of the olefinic proton,<sup>8</sup> this was insufficient to establish the configuration of **3** since the value for the vinyl proton,  $\delta$  6.48, lay between values established for tiglic (ca.  $\delta$  6.7) and angelic (ca.  $\delta$  6) esters.<sup>9</sup> Proof for the structure of **3**, and particularly for its geometric configuration, was provided by an X-ray crystallographic investigation. Figure 6 is a computer-generated perspective drawing of the final X-ray model of the side-chain ester **3**. The X-ray experiment did not define the absolute stereostructure but only the relative one, and the enantiomer shown is an arbitrary choice. The chiral centers are designated (*S*\*)-C(2) and (*R*\*)-C(3), and the C(2)'-C(3)' double bond has the *E* configuration corresponding to tiglic acid. In general, all bond distances and angles agree well with expected values. There is an intermolecular hydrogen bond from O(13)H to O(6)' of 2.73 Å.

The KB and P388 activities of cephalomannine are roughly comparable to those of taxol,<sup>7</sup> which is now undergoing clinical trial.

As indicated above, hydrolysis of cephalomannine produced a series of products which included baccatin V (**5a**) and 10-deacetylbaccatin V (**5b**). Likewise, oxidation of baccatin III (**1c**) with basic manganese dioxide yielded diketone **6a** along with its C-7 $\alpha$  epimer, **6b**, in a ratio of 3.5:1. In both cases, mildly basic reaction conditions could have promoted epimerization at C-7. Strong hydrogen bonding of the 7 $\alpha$ -hydroxyl group to the acyl oxygen of the 4 $\alpha$ -acetate group of **5a** is observed in the crystalline state,<sup>10</sup> and this effect might enhance the stability of the 7 $\alpha$ -epimers of the series in solution. Preliminary results of our investigations of other taxanes indicate that this ep-

(8) Nair, M. D.; Adams, R. *J. Am. Chem. Soc.* 1961, 83, 922.

(9) Herz, W.; Lakshminantham, M. V. *Tetrahedron* 1965, 21, 1711; Morimoto, H.; Sanno, Y.; Oshio, H. *Ibid.* 1966, 22, 3173. Bohlmann, F.; Suwita, A.; Natu, A. A.; Czerson, H.; Suwita, A. *Chem. Ber.* 1977, 110, 3572.

(10) Castellano, E. E.; Hodder, O. J. R. *Acta Crystallogr., Sect. B* 1973, 29, 2566.

Table I. <sup>1</sup>H NMR Spectra of Taxane Derivatives<sup>a</sup>

protons	1a <sup>b</sup>	1b <sup>c</sup>	1c	1d	1f <sup>d</sup>	2 <sup>e</sup>	5a	5b	6a	6b
C-2	5.62 (d, <i>J</i> = 7)	5.63 (d, <i>J</i> = 7)	5.58 (d, <i>J</i> = 7)	5.59 (d, <i>J</i> = 7.5)	5.68 (d, <i>J</i> = 7.5)	5.45 (d, <i>J</i> = 4)	5.71 (d, <i>J</i> = 7.5)	5.71 (d, <i>J</i> = 7.5)	5.72 (d, <i>J</i> = 7)	5.84 (d, <i>J</i> = 7.5)
C-3	3.74 (d, <i>J</i> = 7)	3.76 (d, <i>J</i> = 7)	3.84 (d, <i>J</i> = 7)	3.95 (d, <i>J</i> = 7.5)	3.88 (d, <i>J</i> = 7.5)	3.15 (d, <i>J</i> = 4)	4.01 (d, <i>J</i> = 7.5)	4.04 (d, <i>J</i> = 7.5)	3.95 (d, <i>J</i> = 7)	4.04 (d, <i>J</i> = 7.5)
C-5	4.87 (dd, <i>J</i> = 2, 7)	4.89 (dd, <i>J</i> = 2, 8)	4.94 (dd, <i>J</i> = 2, 8)	4.97 (dd, <i>J</i> = 2, 10)	4.92 (br d, <i>J</i> = 9)	4.18 (br t, <i>J</i> = 3)	4.93 (dd, <i>J</i> = 3, 5)	4.94 (dd, <i>J</i> = 1, 6)	4.97 (dd, <i>J</i> = 2, 9)	4.95 (dd, <i>J</i> = 3, 5)
C-6	2.0 (m)	2.0 (m)	2.4 (m)	2.2 (m)	2.0 (m)	1.8 (m)	2.1 (m)	2.1 (m)	2.6 (m)	2.3 (m)
C-7	4.32 (m)	4.30 (m)	4.4 (m)	4.15 (m)	4.2 (m)	5.45 (dd, <i>J</i> = 5, 11)	3.67 (dt)	3.65 (dt)	4.48 (dd, <i>J</i> = 4, 7)	3.71 (dt)
C-10	6.23 (s)	6.23 (s)	6.28 (s)	5.24 (s)	5.18 (s)	6.19 (d, <i>J</i> = 11)	6.82 (s)	5.48 (s)	6.48 (s)	6.98 (s)
C-13	6.15 (br t, <i>J</i> = 9)	6.18 (br t, <i>J</i> = 8)	4.82 (br t, <i>J</i> = 9)	4.8 (br t, <i>J</i> = 9)	6.17 (br t, <i>J</i> = 7.5)	6.0 (m)	4.8 (m)	4.83 (m)		
C-14	2.5 (m)	2.4 (m)	2.4 (m)	2.4 (m)	2.4 (m)	2.2 (m), 2.5 (dd, <i>J</i> = 9, 15)	2.3 (m)	2.3 (m)	2.68 (d), 3.05 (d, <i>J</i> = 20)	2.69 (d), 3.10 (d, <i>J</i> = 20)
C-16	1.24 (s)	1.22 (s)	1.08 (s)	1.06 (s)	1.22 (s)	1.63 (s)	1.11 (s)	1.08 (s)	1.28 (s)	1.30 (s)
C-17	1.12 (s)	1.12 (s)	1.08 (s)	1.06 (s)	1.12 (s)	1.24 (s)	1.05 (s)	1.08 (s)	1.23 (s)	1.26 (s)
C-18	1.78 (br s)	1.78 (br s)	2.01 (d, <i>J</i> = 1)	2.03 (d, <i>J</i> = 1.5)	1.78 (d, <i>J</i> = 1.5)	2.21 (s) <sup>f</sup>	1.99 (d, <i>J</i> = 1.5)	1.99 (d, <i>J</i> = 1.5)	2.12 (s)	2.03 (s)
C-19	1.65 (s)	1.66 (s)	1.63 (s)	1.70 (s)	1.68 (s)	1.24 (s)	1.63 (s)	1.70 (s)	1.72 (s)	1.67 (s)
C-20	4.12 (d), 4.24 (d, <i>J</i> = 8)	4.14 (d), 4.26 (d, <i>J</i> = 8)	4.11 (d), 4.25 (d, <i>J</i> = 8)	4.14 (d), 4.29 (d, <i>J</i> = 8)	4.18 (d), 4.32 (d, <i>J</i> = 9)	2.29 (d), 3.53 (d, <i>J</i> = 5)	4.35 (d), 4.36 (d, <i>J</i> = 9)	4.39 (d), 4.40 (d, <i>J</i> = 10.5)	4.15 (d), 4.35 (d, <i>J</i> = 8)	4.36 (d), 4.44 (d, <i>J</i> = 9)
OBz	7.46 (m), 8.05 (dd, <i>J</i> = 2, 8)	7.4 (m), 8.09 (dd, <i>J</i> = 2, 8)	7.46 (m), 8.05 (dd, <i>J</i> = 2, 8)	7.52 (m), 8.09 (dd, <i>J</i> = 2, 8)	7.56 (m), 8.12 (dd, <i>J</i> = 2, 8)		7.52 (m), 8.12 (dd, <i>J</i> = 2, 8)	7.55 (m), 8.12 (dd, <i>J</i> = 2, 8)	7.58 (m), 8.10 (dd, <i>J</i> = 2, 8)	7.60 (m), 8.12 (dd, <i>J</i> = 2, 8)
OAc	2.20 (s), 2.32 (s)	2.20 (s), 2.36 (s)	2.20 (s), 2.24 (s)	2.27 (s)	2.35 (s)	1.98 (s), 2.02 (s), 2.07 (s), 2.10 (s), 2.21 (s)	2.20 (s), 2.35 (s)	2.38 (s)	2.22 (s), 2.33 (s)	2.28 (s), 2.30 (s)

<sup>a</sup> Measured in CDCl<sub>3</sub>. Chemical shifts (δ) are expressed in parts per million from Me<sub>4</sub>Si and coupling constants (*J*) in hertz. <sup>b</sup> C-2' H at 4.66 (d), *J* = 3; C-3' H at 5.56 (dd), *J* = 3, 9; C-3' Ph at 7.34 (s); NH at 6.52 (d), *J* = 9; C-2' Me at 1.78 (br s); C-4'' protons at 1.70 (d), *J* = 7; C-3'' H at 6.37 (d), *J* = 7. <sup>c</sup> C-2' H at 4.73 (d), *J* = 3; C-3' H at 5.73 (dd), *J* = 3, 9; C-3' Ph at 7.40 (s); NH at 7.01 (d), *J* = 9; NBz at 7.4 (m) and 7.69 (dd), *J* = 2, 8. <sup>d</sup> C-2' H at 4.69 (d), *J* = 3; C-3' H at 5.60 (dd), *J* = 3, 9; C-3' Ph at 7.38 (s); NH at 6.62 (d), *J* = 9; C-2' Me at 1.75 (s); C-4'' protons at 1.7 (not resolved from other signals); C-3'' H at 6.43 (br dd), *J* = 7, 3. <sup>e</sup> C-9 H at 5.99 (d), *J* = 11. <sup>f</sup> Uncertain because of the six acetate signals.

imerization occurs also under neutral conditions and that it is reversible.

$\alpha$ -Substituted allylic esters are usually solvolyzed by alkyl oxygen cleavage instead of by the more common acyl oxygen mechanism.<sup>11</sup> Accordingly, formation of methyl ester 3 under mild solvolytic conditions may occasion some surprise. However, steric constraints at C-11 may preclude formation of a planar carbonium ion so that alkyl oxygen cleavage is not facilitated. Furthermore, an  $\alpha$ -hydroxy substituent is available to aid interesterification by a B<sub>AC</sub>2 mechanism.

### Experimental Section

**General Procedures.** TLC was accomplished with silica gel 60 F254 plates (0.25 mm thick, E. Merck). The plates were developed with CHCl<sub>3</sub>-MeOH (95:5 or 100:10) and were visualized by charring with 1% K<sub>2</sub>Cr<sub>2</sub>O<sub>7</sub> in 40% H<sub>2</sub>SO<sub>4</sub>. Hi Flosil (60/200 mesh, Applied Science) was used for column chromatography. High-pressure LC was performed with a Waters Associates, Inc., Model ALC/PC-201 instrument equipped with a 7.8 × 300 mm, C<sub>18</sub>,  $\mu$ -Bondapak column. Countercurrent distribution was conducted by means of a 200-tube Craig-Post apparatus with 40 mL of each phase per tube. Weight distribution curves were established by evaporating and weighing the contents of every tenth tube. IR spectra were recorded on a Perkin-Elmer Model 700 instrument with 1% CHCl<sub>3</sub> solutions. Proton NMR spectra were determined with either a Varian HA-100 or a Bruker WH-90 instrument; CDCl<sub>3</sub> solutions were used with tetramethylsilane as an internal standard. Low-resolution mass spectra were obtained with a Du Pont (CEC) 21-492-1 spectrometer and high-resolution mass spectra with either a Nuclide 12-90-DF or Kratos MS-30 instrument. Melting points were determined with a Fischer-Johns block and are uncorrected.

**Plant Material.** Roots, stems, and leaves of *Taxus wallichiana* Zuccarini were collected near Shillong in the state of Assam, India, in Dec 1972. They were stored at 1 °C until they were ground for extraction.

**Extraction Procedure.** The ground plant material (19 kg) was extracted five to seven times by percolation with 95% ethanol. The ethanol extracts were concentrated to 4.478 kg, and the resulting residue was diluted with water to a volume of 12 L. This aqueous ethanol solution was extracted with petroleum ether (bp 30–60 °C) to remove lipid material and then was extracted with chloroform. The combined CHCl<sub>3</sub> extracts, upon evaporation, yielded 264 g of solid material (F188), which was found to be KB and PS active.

**Chromatographic Separations.** The chloroform solubles (F188) were chromatographed batchwise. In each run, a 25–40-g portion of F188 was dissolved in 30–50 mL of CHCl<sub>3</sub>-MeOH (95:5) and was applied to a 6 × 72 cm column packed with 460 g of silica gel. The column was then eluted with 2 L of CHCl<sub>3</sub>-MeOH (95:5) followed by 2 L of CHCl<sub>3</sub>-MeOH (1:1) in 32 fractions of 125 mL each. After these 32 fractions from each run were monitored by TLC, they were combined appropriately into five fractions (F191–F196); KB activity was found in F191 through F194, inclusive.

F193 (67.2 g) was applied in 7–8-g batches to a 4 cm × 70 cm column packed with 240 g of silica gel. Each column was successively eluted with 1 L of CHCl<sub>3</sub> followed by 1 L of CHCl<sub>3</sub>-MeOH (98:2), 0.6 L of CHCl<sub>3</sub>-MeOH (95:5), and finally 1 L of MeOH. After the collected fractions were monitored by TLC, they were combined appropriately and evaporated to yield fractions F211–F216 (Figure 1). F191 and F192 were chromatographed similarly to yield F206–F210. KB activity was found in F209, F210, and F214–F216.

**Countercurrent Distributions.** F215 (10 g) was subjected to CCD with a four-component, biphasic system prepared by mixing ethyl acetate, hexane, methanol, and water in the ratio 60:40:35:65. Eight hundred transfers were applied; after the 200 transfers of the fundamental series were complete, 600 additional transfers were decanted into a fraction collector. Fractions were

combined for KB assay and further processing as indicated on the weight distribution curve (Figure 3).

F214 (8.9 g) was processed by CCD in the same manner as F215, except that a portion (1.2 g) was insoluble in both solvent phases and was excluded. Fractions from the weight distribution were combined with corresponding fractions (P1–P7) from F215. The only KB-active fraction in this series was P1. The insoluble portion (F240) was inactive in KB and was not examined further.

P1 (5.0 g) was subjected to another CCD, but with a solvent system prepared by mixing ethyl acetate, hexane, methanol, and water (40:60:65:35). After 600 transfers and TLC monitoring, the contents of fundamental series tubes 100–200 were replaced with fresh upper and lower phases, and the distribution was continued for 600 transfers in the recycle mode. The contents of the 200 tubes (ca. 3 g) were pooled as in Figure 4; all but one of these fractions were KB active. By contrast, none of the fractions in the decant series (ca. 2 g) were active.

**Isolation and Characterization of Cephalomannine (1a).** High-pressure LC of F257 (Figures 2 and 4) with MeOH-H<sub>2</sub>O (60:40) gave four fractions (B1–B4). Evaporation of B3 gave (1.63 × 10<sup>-3</sup>% yield, based on plant material) a white solid (K263, mp 184–186 °C) after it was recrystallized from aqueous MeOH: [ $\alpha$ ]<sub>D</sub><sup>20</sup> -41° (c 0.39, MeOH); NMR, see Table I; mass spectrum (70 eV), *m/e* (relative intensity) 404 (5), 386 (2), 326 (3), 308 (2), 218 (16), 200 (28), 188 (33), 122 (27), 106 (19), 105 (100), 91 (43), 83 (37), 77 (34), 55 (38), 43 (47); field-desorption mass spectrum, *m/e* 831 (M<sup>+</sup>; C<sub>45</sub>H<sub>58</sub>NO<sub>14</sub> requires 831).

**Isolation and Identification of Taxol (1b).** Evaporation of B4 yielded a white solid, K264 (1.08 × 10<sup>-3</sup>% yield, based on plant material), of melting point 198–203 °C after it was recrystallized from aqueous MeOH (lit.<sup>6</sup> mp 213–216 °C); [ $\alpha$ ]<sub>D</sub><sup>23</sup> -42° (c 0.37, MeOH) (lit.<sup>6</sup> [ $\alpha$ ]<sub>D</sub><sup>20</sup> -49°); NMR values (see Table I) were similar to literature values for taxol;<sup>6</sup> mass spectrum (70 eV), *m/e* (relative intensity) 404 (6), 386 (2), 326 (3), 308 (2), 268 (2), 240 (2), 222 (27), 210 (9), 193 (29), 122 (21), 105 (100), 91 (14), 77 (23), 42 (35).

**Isolation and Identification of Baccatin III (1c).** High-pressure LC of fraction P2 with the solvent system MeOH-H<sub>2</sub>O (1:1) yielded six fractions. Fraction 2 yielded a solid: mp 229–231 °C after recrystallization from CHCl<sub>3</sub> (lit.<sup>12</sup> mp 232–234 °C); IR (CHCl<sub>3</sub>) 3540, 1720 cm<sup>-1</sup>; [ $\alpha$ ]<sub>D</sub><sup>23</sup> -54° (c 0.41, MeOH) [lit.<sup>12</sup> [ $\alpha$ ]<sub>D</sub><sup>23</sup> -93° (solvent unspecified)]; NMR, Table I; mass spectrum (70 eV), *m/e* (relative intensity) 586 (M<sup>+</sup>, 0.1), 527 (M<sup>+</sup> - OAc, 11), 526 (M<sup>+</sup> - HOAc, 3), 508 (3), 467 (2), 404 (1), 386 (1), 221 (1), 193 (6), 177 (4), 151 (8), 149 (7), 122 (9), 106 (9), 105 (100), 77 (20), 55 (4), 43 (41); *m/e* 527.2266 (M<sup>+</sup> - OAc; C<sub>29</sub>H<sub>36</sub>O<sub>9</sub> requires 527.2281).

Mild acetylation of 1c (acetic anhydride-pyridine overnight at 26 °C) gave the 13-*O*-acetate 1e. NMR showed the expected downfield shift of the C-13 proton from  $\delta$  4.8 to 5.7: mass spectrum (70 eV), *m/e* (relative intensity) 569 (M<sup>+</sup> - OAc, 13), 356 (11), 219 (18), 137 (55), 105 (100).

**Isolation and Identification of 1 $\beta$ -Hydroxybaccatin I (2).** High-pressure LC of fraction B1 with MeOH-H<sub>2</sub>O (1:1) as the eluting solvent gave eight fractions, C1–C8. Evaporation of C4 provided a white solid (K265): 7.88 × 10<sup>-4</sup>% yield from plant material; mp 257–262 °C after recrystallization from aqueous MeOH (lit.<sup>13</sup> mp 273 °C dec); NMR, Table I; on TLC, this compound chars a transient blue color at 70 °C (which turns black at higher temperatures); mass spectrum, *m/e* 533.2372 (M<sup>+</sup> - HOAc - OAc; C<sub>28</sub>H<sub>37</sub>O<sub>10</sub> requires 533.2386), 490.2207 (M<sup>+</sup> - 2 HOAc - C<sub>2</sub>H<sub>2</sub>O; C<sub>26</sub>H<sub>34</sub>O<sub>9</sub> requires 490.2202), 472.2093 (M<sup>+</sup> - 3 HOAc; C<sub>26</sub>H<sub>32</sub>O<sub>8</sub> requires 472.2097), 430.1991 (M<sup>+</sup> - 3 HOAc - C<sub>2</sub>H<sub>2</sub>O; C<sub>24</sub>H<sub>30</sub>O<sub>7</sub> requires 430.1991).

Anal. Calcd for C<sub>32</sub>H<sub>44</sub>O<sub>14</sub>: C, 58.89; H, 6.79. Found: C, 58.42; H, 6.73.

**Methanolysis of Cephalomannine (1a).** (A) **With Methanolic Sodium Bicarbonate.** A 37-mg portion of 1a was dissolved in 4 mL of 1% NaHCO<sub>3</sub> in CH<sub>3</sub>OH-H<sub>2</sub>O (3:1) at ambient temperature. After reacting for 5 h, the mixture was extracted repeatedly with CHCl<sub>3</sub>. From the combined CHCl<sub>3</sub> extracts were

(11) Gould, E. S. "Mechanism and Structure in Organic Chemistry"; Holt Dryden: New York, 1959; p 342.

(12) Della Casa de Marcano, D. P.; Halsall, T. G.; Hornby, G. M. *J. Chem. Soc., Chem. Commun.* 1970, 216; Della Casa de Marcano, D. P.; Halsall, T. G. *Ibid.* 1975, 365.

(13) Della Casa de Marcano, D. P.; Halsall, T. G. *J. Chem. Soc., Chem. Commun.* 1970, 1381.

obtained six products which were separated by TLC and identified by NMR and mass spectra: baccatin III (1c), 4.9 mg (NMR, Table I; mass spectrum, see above); 10-deacetyl baccatin III (1d), 4.6 mg [mp 234–236 °C; NMR, Table I; mass spectrum (70 eV),  $m/e$  (relative intensity) 544 ( $M^+$ , 0.2), 527 ( $M^+ - OH$ , 0.5), 526 ( $M^+ - H_2O$ , 3), 404 (1), 221 (1), 193 (1), 177 (5), 151 (4), 149 (9), 140 (13), 124 (11), 122 (13), 106 (9), 105 (100), 77 (24), 55 (7), 43 (40);  $m/e$  526.2194 ( $M^+ - H_2O$ ;  $C_{29}H_{34}O_9$  requires 526.2202)]; 10-deacetylcephalomanine (1f), 1.6 mg (NMR, Table I); methyl ester 3, 6.6 mg (NMR, see below; mass spectrum, Figure 5); baccatin V (5a), 4.5 mg [NMR, Table I; mass spectrum,  $m/e$  (relative intensity) 586 ( $M^+$ , 0.2) 8 527 ( $M^+ - OAc$ , 12), 526 ( $M^+ - HOAc$ , 2), 508 (5), 467 (1), 404 (1), 386 (1), 256 (6), 221 (0.9), 193 (3), 188 (21), 177 (4), 151 (6), 149 (11), 137 (5), 129 (6), 122 (27), 106 (18), 105 (100), 77 (28), 57 (22), 55 (30), 43 (35);  $m/e$  527.2269 ( $M^+ - OAc$ ;  $C_{29}H_{36}O_9$  requires 527.2281)]; 10-deacetyl baccatin V (5b), 3.3 mg [NMR, Table I; mass spectrum,  $m/e$  (relative intensity) 544 ( $M^+$ , 0.3), 527 ( $M^+ - OH$ , 2), 526 ( $M^+ - H_2O$ , 2), 404 (1), 256 (1), 221 (1), 193 (3), 188 (3), 177 (5), 151 (5), 149 (10), 140 (10), 137 (8), 122 (19), 106 (23), 105 (100), 77 (26), 57 (9), 55 (12), 43 (28);  $m/e$  527.2261 ( $M^+ - OH$ ;  $C_{29}H_{36}O_9$  requires 527.2281), 526.2198 ( $M^+ - H_2O$ ;  $C_{29}H_{34}O_9$  requires 526.2202)].

**(B) With Sodium Methoxide.** A 67-mg portion of 1a was treated with 3 mL of 0.5 M NaOMe in MeOH at 25 °C for 3 h. The reaction was then quenched with 30 mL of 5% HOAc and extracted four times with 10-mL portions of  $CHCl_3$ . The combined  $CHCl_3$  extracts were washed with 5%  $Na_2CO_3$  and then with water. After being dried and evaporated this  $CHCl_3$  extract yielded 23 mg of crude product. Preparative TLC of the product and recrystallization from  $CHCl_3$  afforded 8 mg of 3: mp 129–132 °C; IR ( $CHCl_3$ ) 3480, 3410 (OH, NH), 1710 (ester C=O), 1640 (amide C=O), 1605 (C=C)  $cm^{-1}$ ; NMR  $\delta$  1.72 (3 H, br d,  $J = 7$  Hz, H-4''), 1.82 (3 H, br s, C-2' Me), 3.78 (3 H, s, ester  $CH_3$ ), 4.52 (1 H, d,  $J = 2$  Hz, H-2'), 5.54 (1 H, dd,  $J = 8, 2$  Hz, H-3'), 6.48 (1 H, br q,  $J = 7$  Hz, H-3''), 6.5 (1 H, br d,  $J = 8$  Hz, NH), 7.31 (5 H, br s, C-3' Ph); after  $D_2O$  exchange overnight, the NH signal disappeared, and the apparent quartet at  $\delta$  5.54 collapsed into a doublet ( $J = 2$  Hz); mass spectrum (70 eV),  $m/e$  (relative intensity) 218 ( $M^+ - CO_2Me$ , 1), 200 (4), 188 (18), 106 (15), 83 (100), 55 (52); see also Figure 5;  $m/e$  218.1168 ( $M^+ - CO_2Me$ ;  $C_{16}H_{16}NO_2$  requires 218.1181).

Products from the diterpene moiety were complex and remain unidentified.

**Methanolysis of Taxol (1b).** A 35-mg sample of 1b was reacted with 1.5 mL of 0.5 M NaOMe in MeOH for 3 h. The crude product was isolated as described for 1a. Preparative TLC and crystallization from  $CHCl_3$  gave 4: mp 184–185 °C (lit.<sup>6</sup> mp 183–185 °C); NMR  $\delta$  3.25 (1 H, d,  $J = 4$  Hz, OH), 3.85 (3 H, s, ester  $CH_3$ ), 4.64 (1 H, dd,  $J = 4, 2$  Hz, H-2'), 5.74 (1 H, dd,  $J = 10, 2$  Hz, H-3'), 7.0 (1 H, br d,  $J = 10$  Hz, NH), 7.48 (8 H, m, C-3' Ph and NBz), 7.85 (2 H, dd,  $J = 2.3, 8$  Hz, ortho H on NBz); for literature values, see ref 6; mass spectrum (70 eV),  $m/e$  (relative intensity) 240 ( $M^+ - CO_2Me$ , 2), 225 (5), 210 (43), 105 (100) 77 (32).

**Oxidation of Baccatin III.** A 43-mg sample of 1c was oxidized with 500 mg of basic  $MnO_2$ <sup>14</sup> in  $CHCl_3$  solution for 18 h. Products were recovered by centrifugation and preparative TLC [solvent  $CHCl_3$ -MeOH (95:5)]. Two isomeric diketones were isolated: 6a (22 mg) and 6b (6 mg). Compound 6a was crystallized from ethyl ether-petroleum ether: mp 210–212 °C (lit.<sup>6</sup> mp 210–212 °C); IR ( $CHCl_3$ ) 3550 (OH), 1725 (C=O), 1680 (conj C=O); NMR, Table I; mass spectrum (70 eV),  $m/e$  (relative

intensity) 584 ( $M^+$ , 5), 542 (2), 524 (2), 420 (3), 177 (5), 165 (6), 139 (5), 106 (8), 105 (100), 77 (14), 43 (27);  $m/e$  584.2258 ( $M^+$ ;  $C_{31}H_{36}O_{11}$  requires 584.2257).

Compound 6b was obtained as a glassy solid: IR ( $CHCl_3$ ) 3480 (OH), 1750, 1717, 1680 (C=O); NMR, Table I; mass spectrum (70 eV),  $m/e$  (relative intensity) 584 ( $M^+$ , 19), 542 (6), 524 (8), 420 (5), 177 (8), 165 (16), 139 (7), 106 (8), 105 (100), 77 (3), 60 (3), 43 (7);  $m/e$  584.2251 ( $M^+$ ;  $C_{31}H_{36}O_{11}$  requires 584.2257), 542.2145 ( $M^+ - C_2H_2O$ ;  $C_{29}H_{34}O_{10}$  requires 542.2152), 524.2041 ( $M^+ - HOAc$ ;  $C_{29}H_{32}O_9$  requires 524.2046).

**X-ray Crystallographic Study of Side-Chain Ester 3.** Preliminary X-ray photographs showed monoclinic symmetry and accurate lattice constants of  $a = 7.403$  (1) Å,  $b = 9.653$  (2) Å,  $c = 11.675$  (4) Å, and  $\beta = 63.59$  (2)° were determined by a least-squares fit of 15 moderate, diffractometer-measured,  $2\theta$  values. The presence of chirality and the systematic extinctions were uniquely accommodated by space group  $P2_1$ , with one molecule of  $C_{16}H_{19}NO_4$  forming the asymmetric unit ( $\rho_c = 1.3$  g/cm<sup>3</sup>). All unique diffraction maxima with  $2\theta \leq 114^\circ$  were surveyed on a computer-controlled, four-circle diffractometer using a variable-speed,  $1^\circ \omega$  scan and graphite-monochromated Cu K $\alpha$  radiation (1.54178 Å). A total of 1090 reflections was surveyed in this fashion, and after correction for Lorentz, polarization, and background effects, 1050 (95%) were judged observed [ $|F_o| \geq 3\sigma(F_o)$ ]. No corrections were deemed necessary for absorption or decomposition.

A phasing model was achieved by using a multisolution, weighted, tangent-formula approach.<sup>15</sup> The most probably solution yielded the nonhydrogen framework. Hydrogens were located on  $\Delta F$  syntheses and by calculated positions. Full-matrix, least-squares refinement with anisotropic nonhydrogen atoms and isotropic hydrogens have currently converged to a standard crystallographic residual of 0.070 for the observed data (see the supplementary material for additional crystallographic data).

**Acknowledgment.** We thank Dr. John Douros, National Cancer Institute, Bethesda, MD, for a reference sample of taxol, Dr. Robert Perdue, USDA, Beltsville, MD, for supplying plant material, R. D. Plattner and Dr. W. K. Rohwedder for electron-impact mass spectra, Dr. David Brent, Burroughs-Wellcome Laboratories, Research Triangle Park, NC, for a field-desorption mass spectrum, and Ms. Clara Johnson for combustion analyses. The National Institutes of Health furnished partial support of this work (Grant No. CA-24487) to J.C. and the National Science Foundation provided a fellowship for E.A.

**Registry No.** 1a, 71610-00-9; 1b, 33069-62-4; 1c, 27548-93-2; 1d, 32981-86-5; 1e, 76446-91-8; 1f, 76429-85-1; 2, 30244-37-2; 3, 71610-01-0; 4, 32981-85-4; 5a, 31077-81-3; 5b, 71629-92-0; 6a, 32981-89-8; 6b, 76497-09-1.

**Supplementary Material Available:** Table of fractional coordinates, and thermal parameters (Table 1), bond distances (Table 2), and bond angles (Table 3) (3 pages). Ordering information is given on any current masthead page.

(15) The following library of crystallographic programs was employed: MULTAN, Germain, G.; Main, P.; Woolfson, M. M. *Acta Crystallogr., Sect. B* 1970, B26, 274; Woolfson, M. M. *Acta Crystallogr., Sect. A* 1977, A33, 219; ORFLS (locally modified), Busing, W.R.; Levy, H. A. Report ORNL-TM-305; Oak Ridge National Laboratory: Oak Ridge, TN; ORFFE, Busing, W. R.; Levy, H. A., Publication ORNL-59-12-3; Oak Ridge National Laboratory: Oak Ridge TN; ORTEP, Johnson, C. K. Report ORNL-TM-3794; Oak Ridge National Laboratory: Oak Ridge, TN.

(14) Goldman, I. M. *J. Org. Chem.* 1969, 34, 1979.